



© 2022 Madera - MaderaShop.com

# MADERRA

## Hidden Bookshelf Doors

### INSTALLATION INSTRUCTIONS.

Please read this entire manual before you begin.



# INSTALLATION INSTRUCTIONS.

Please read this entire manual before you begin.

## ⚠️ WARNING!

This product contains small parts that can be a choking hazard. Do not let children play with any of these small parts! Keep children away from the work area during installation.

## ⚠️ CAUTION!

This product is intended to be installed by professional installation contractors or persons familiar with the tools and methods required for this installation. If you are not sure about your ability to perform this installation, you must contact a professional. Maderra is not responsible for damage or injury caused by incorrect installation or improper use.

## ⚠️ CAUTION!

Do not use this product in any way, or for any purpose, that is not specifically described in these instructions. Maderra is not responsible for damage or injury caused by incorrect installation or improper use.

## ⚠️ WARNING!

Do not install or place Bookshelf Door or wood parts close to fire or heat.

## ⚠️ CAUTION!

Two people required for some parts of the installation process.

## SUMMARY - INSTALLATION INSTRUCTIONS BROCHURE

A. Remove old door.....	3
B. Pallet Content for Double Doors.....	3
C. Install Bookshelf Door Frame.....	4
D. Install Bookshelf Door Frame into the Door Entrance.....	5
E. Attach the Bookcase to the Bookshelf Door Frame.....	5
F. Make Final Adjustments.....	6
G. Installing features .....	6
↳ Hardware, Back Casing, Mirror, Lock Mechanism.....	7

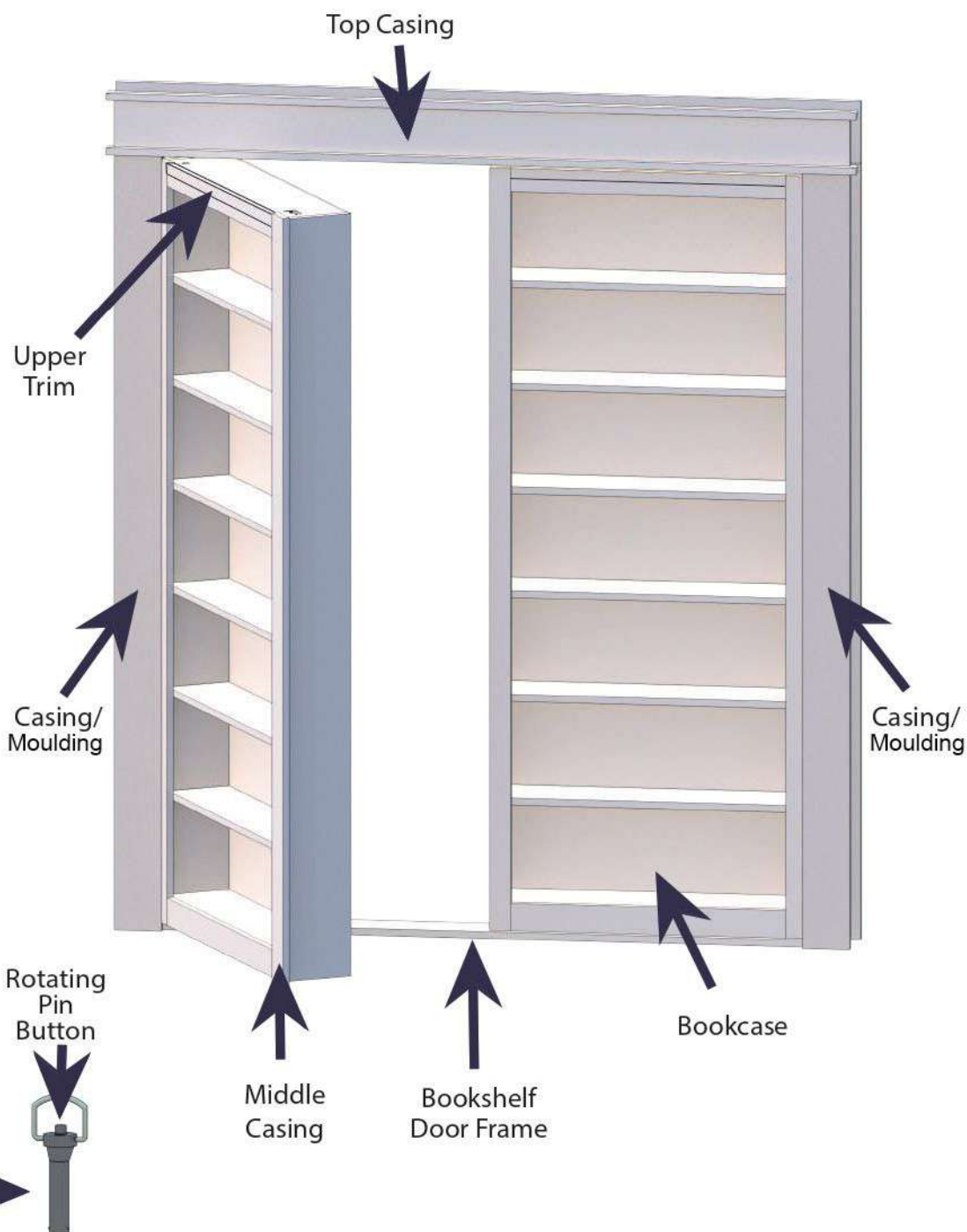



## A. Remove old door.

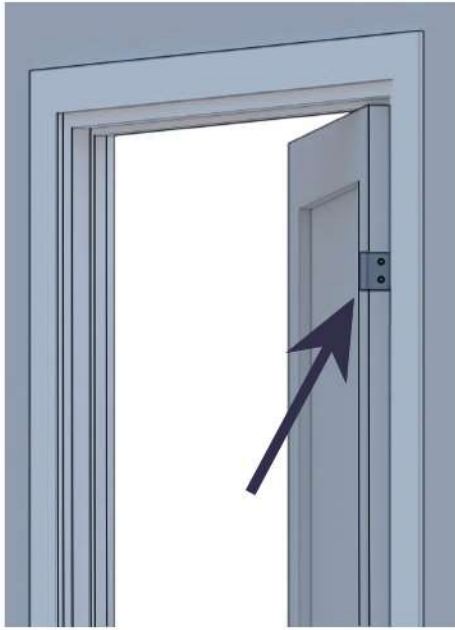

1. Remove Hinges and Door.



2. Remove Door Stops.

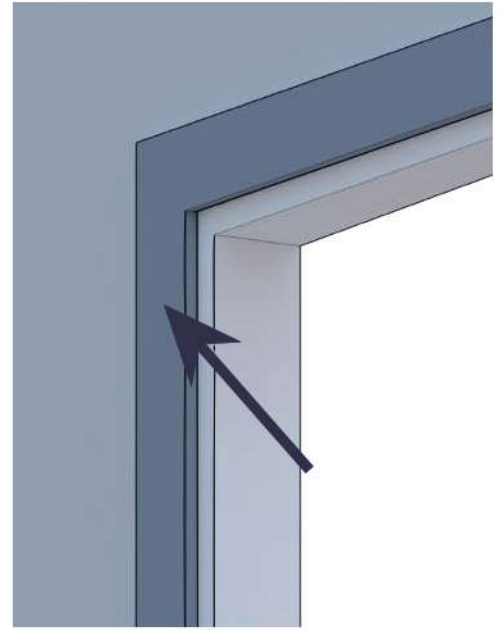

3. Remove Door Casing.

## B. Pallet Content for Double Doors.

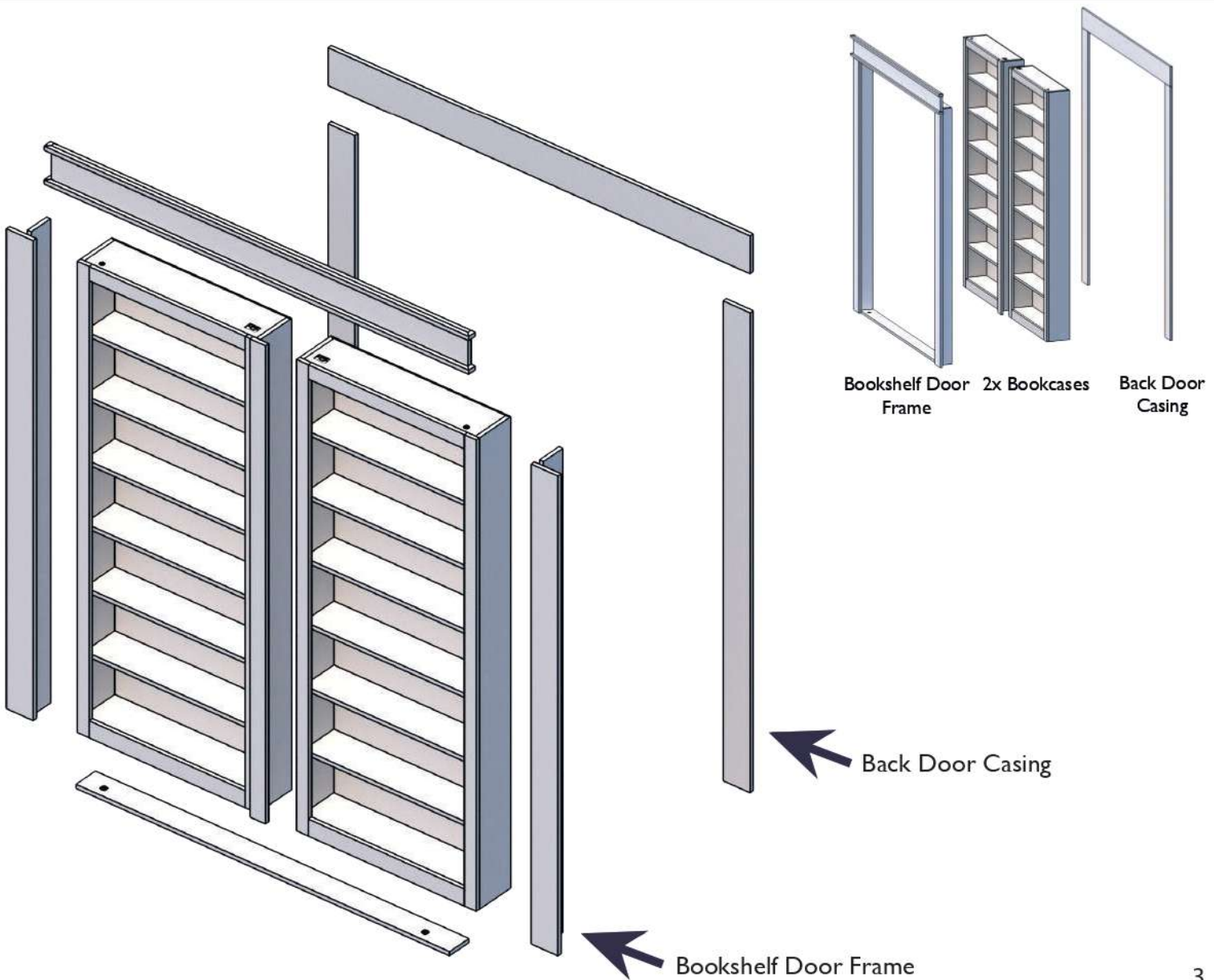

Bookshelf Door Frame    2x Bookcases    Back Door Casing

Back Door Casing

Bookshelf Door Frame

## C. Install Bookshelf Door Frame.

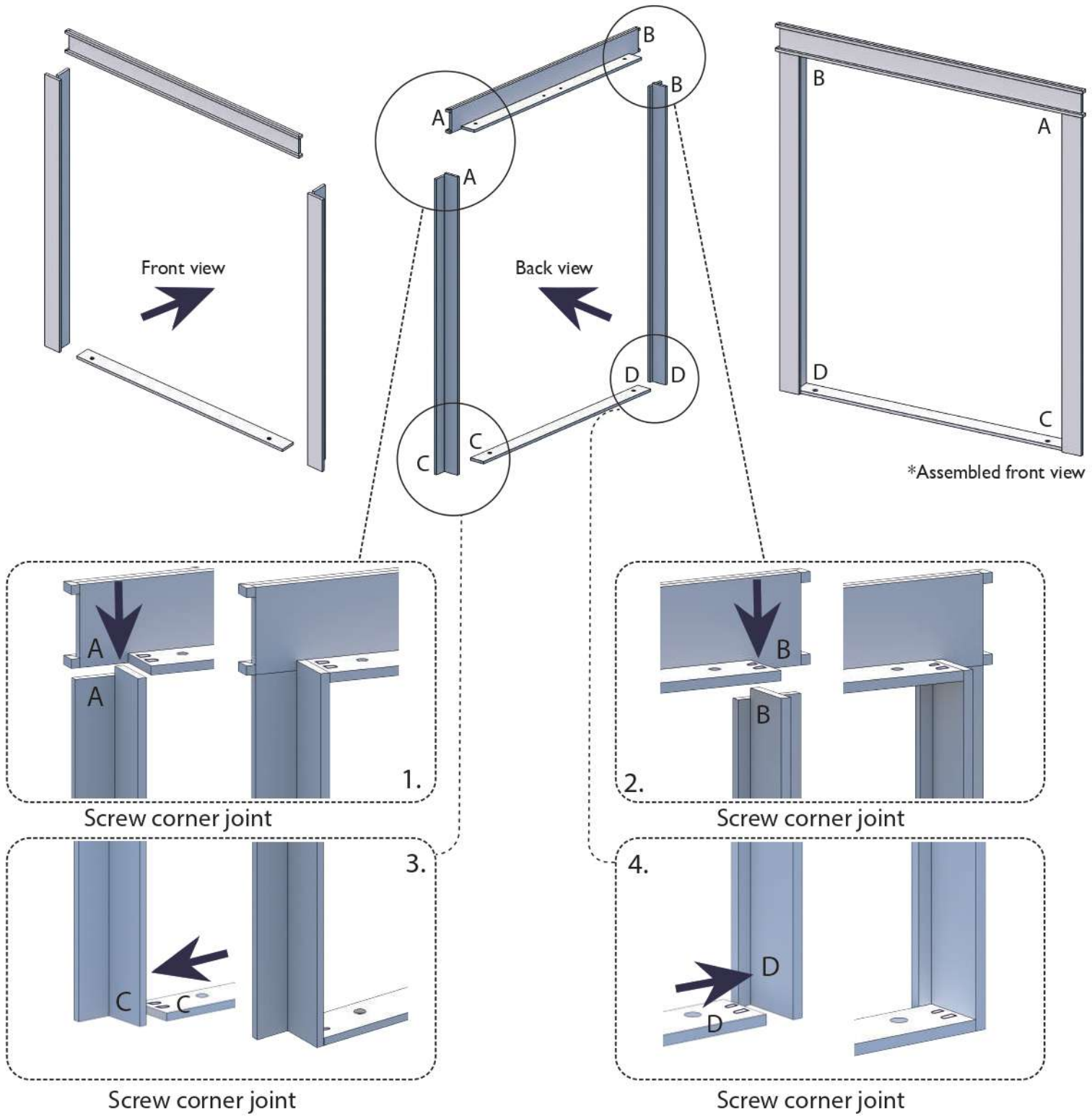

### ⚠ CAUTION!

Keep children away from the work area during installation.

What you need:



Square Drill Bit



Drill

## D. Install Bookshelf Door Frame into the Door Entrance.

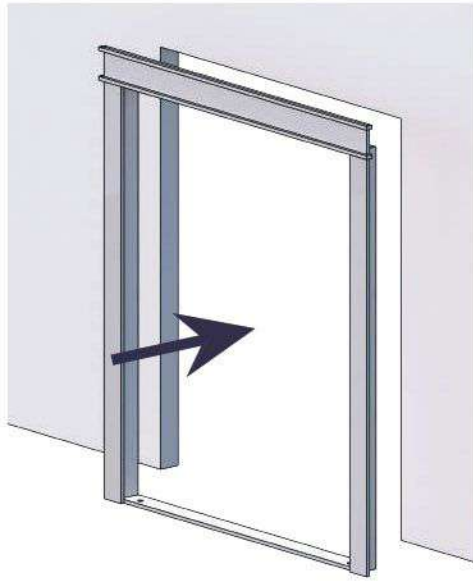

1. Insert the Bookshelf Door Frame into your door entrance.

\* By this point, your door entrance should NOT have Door Stops and Door Casing.



2. Place screws on the side frame of your door, so it attaches to your existing door frame.



3. If the wall or your existing rough opening or door frame is not leveled or straight, you will need to shim the door to level it.

## E. Attach the Bookcase to the Bookshelf Door Frame.

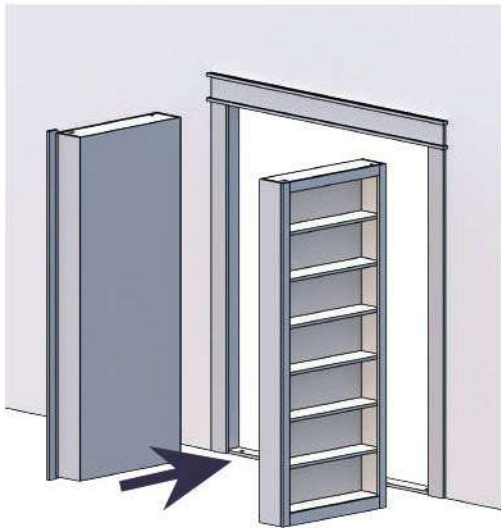

1. Place the Bookcase in position by aligning the bottom shaft into the Rotating Pivot Mechanism.

### ! CAUTION!

Two people are required for this whole part of the installation process.

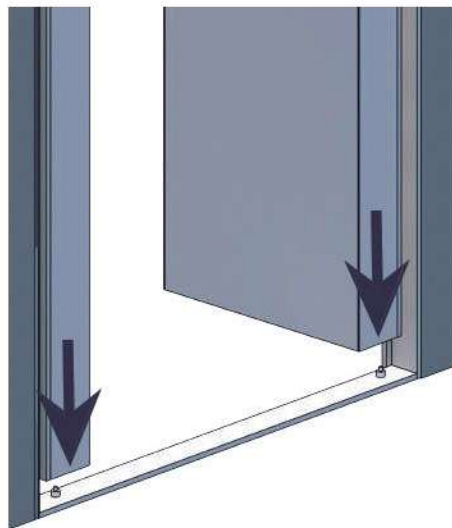

2. This part required the help of another person. Remember the Bookshelf Doors can be heavy!

### ! SAFETY TIPS

Work with one Bookcase at a time.

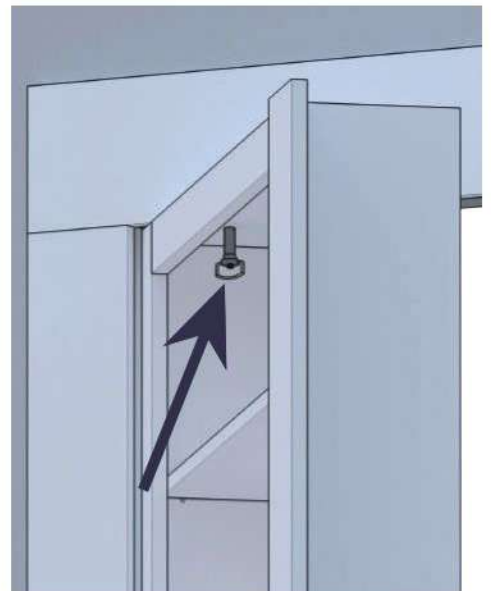

3. Align the upper Bookcase Pin Hole with the Frame Hole and insert the Pin by pushing the Pin Bottom. Repeat this process for the other Bookcase.



## F. Make Final Adjustments.



1. If, after installation, you encounter a gap between the Top Casing and the Middle Casing. You will need to unscrew the Middle Casing from behind and lift it until the gap disappears. Then attach the Middle Casing back to the Bookshelf Door by screwing it in place. (At times, you may be required to nail in the casing if your door doesn't have screws.)

2. Place Upper Trim back by screwing it to seal the gap between Top Casing and Bookcase.

## G. Installing features.



1. If your Bookshelf Door has Bottom Cabinets and you ordered cabinet hardware, now is the time to install them.

2. If you ordered a Back Door Casing, now is the time to install it! We recommend a to work with one piece at the time and have a layout plan before you start screwing the Back Casing in the Wall

3. If you ordered your Bookshelf Door with Mirror behind. Never face the mirror down or put Pressure on the mirror.

# Push Button Electromagnetic Wire Diagram

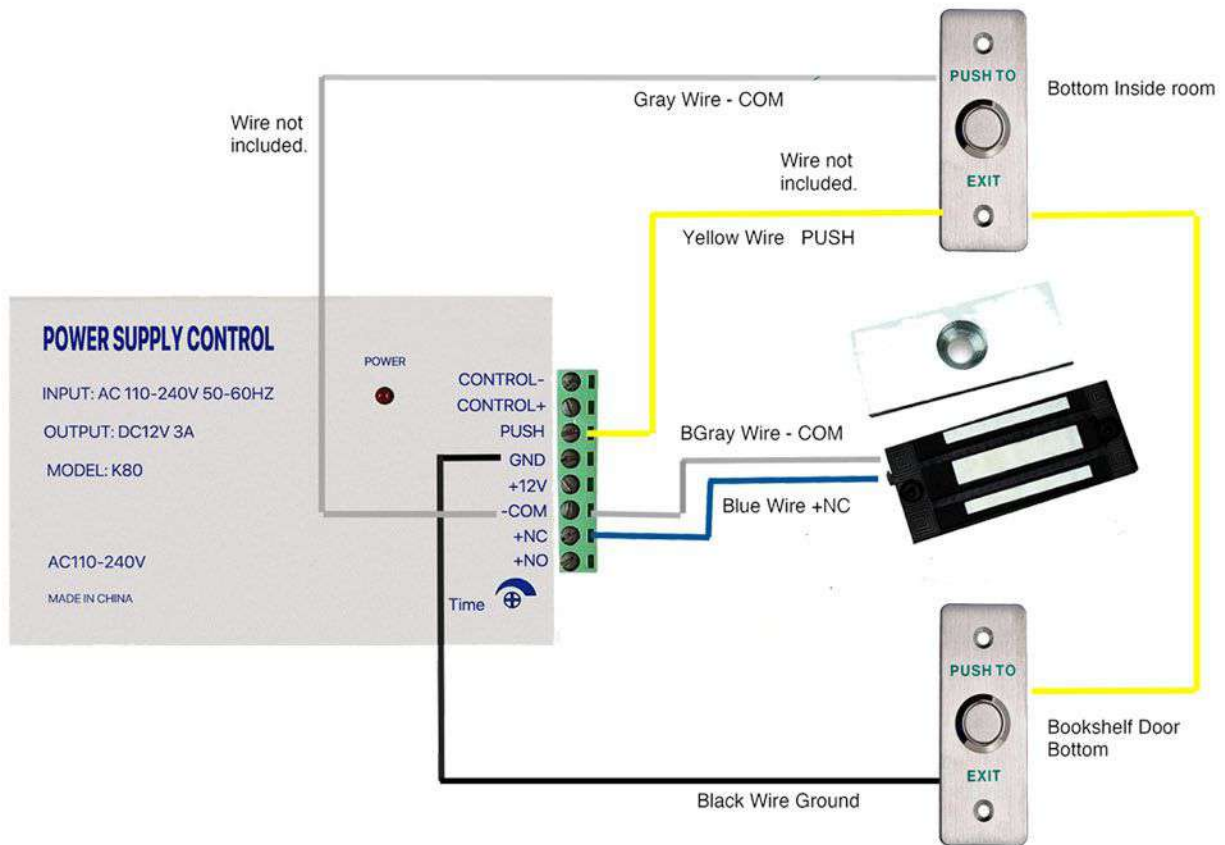

# Electromagnetic Finger Print Reader Wire Diagram

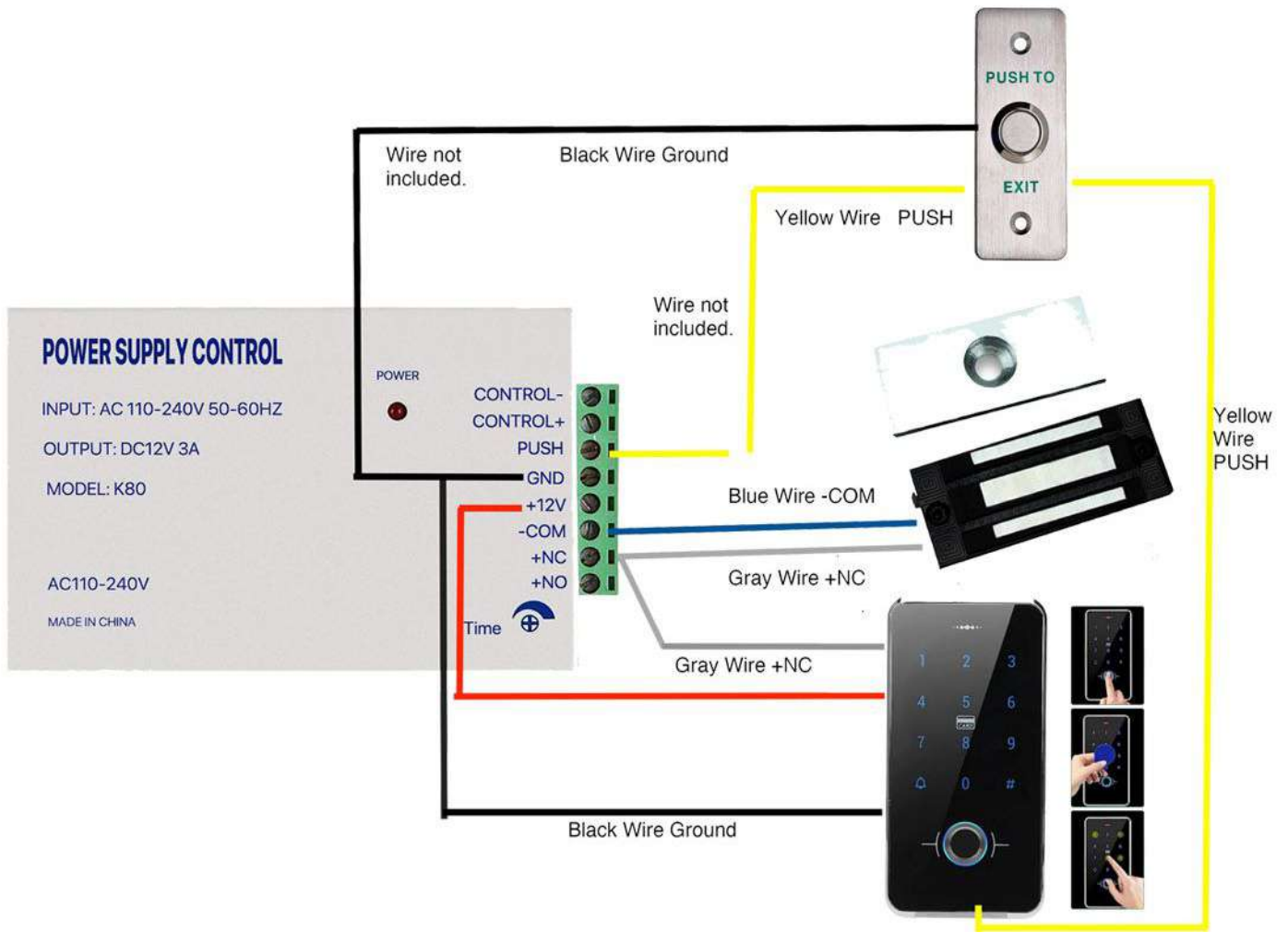

### Add a finger print

- Step 1 - Press: #
- Step 2 - Enter Programing Password: 123456
- Step 3 - Enter: 1
- Step 4 - Enter 001
- Step 5 - Press Fingerprint 3 times

If you want to add additional user, repeat the same steps mentioned in the step above with the exception of step 4. Each new additional the number you type will increase by one number.

Example: For a second user, you will enter 002. For a third user you will enter 003. For a forth user you will enter 004. You can add upto 125 user



### Add a cards or key fobs

- Step 1 - Press: #
- Step 2 - Enter Programing Password: 123456
- Step 3 - Enter: 1
- Step 4 - Enter 001
- Step 5 - Swipec Card or fob

If you want to add additional cards or fobs, repeat the same steps mentioned in the step above with the exception of step 4. Each new card or fob the number you type will increase by one number.

Example: For a second card/fob, you will enter 002. For a third card/fob you will enter 003. For a forth card/fob you will enter 004. You can add upto 125 cards/fobs.



### Modify Opening Password

- Step 1 - Press: #
- Step 2 - Enter Programing Password: 123456
- Step 3 - Enter: 2
- Step 4 - Enter: ( Enter a 4 digit Password of your choice)
- Step 5 - Re enter the the password you created in step 4



FACTORY PASSWORD **7890**  
PROGRAMMING PASSWORD **123456**



CAN REGISTER UP TO 125 USERS

## Lock Mechanism

4. For an easy installation experience, we send all our Lock Mechanisms already installed to the Bookshelf Door.

## TROUBLE SHOOTING

In case your door does not lock, we recomand the following:

- Check to make sure the wires are securely tightened to the correct terminal block
- Check that the power supply is connected and operating properly
- Make sure the lock switch is wired correctly

## ! WARNING!

Maderra recommends a licensed and trained electrician whenever wiring is involved.